



karmetal
SAWlutions





**KMT CRAFT 250X300 DM
MANUAL DOUBLE MITER
BAND SAW MACHINE**

*Photo may feature machine with optional accessories

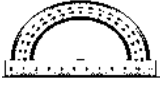

KMT CRAFT 250X300 DM MANUAL DOUBLE MITER BAND SAW MACHINE

CUTTING CAPACITY

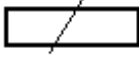
	0°	45°	60°	-45°
	250 mm	200 mm	125 mm	220 mm
	220 mm	190 mm	120 mm	200mm
	200 x 310 mm	220 x 190 mm	200 x 120 mm	220 x 200 mm

TECHNICAL SPECIFICATIONS

Main Motor	: 1,5kW
Gearbox	: Worm Gear Reducer PMRV 063
Hydraulic Motor	: 0,37kW
Hydraulic Tank Capacity	: 12 lt
Coolant Motor	: 0,12kW
Coolant Tank Capacity	: 20 lt
Blade Speed	: 25 -90 m/min
Blade Dimensions	: 3.000 x 27 x 0,9 mm
Machine Weight	: 370 kg
Machine Dimensions	: 740 x 1750 x 1450 mm
Table Height	: 960 mm

STANDARD ACCESSORIES

Manuel Control Panel

Only control panel with buttons
Easy control



Inverter

Provides to adjust blade speed up to
workpiece diameter, thickness and hardness.



Swarf Brush

Removes swarfs to keep clean the
wheels and blade.



Double Miter



Fast Clamping Vise



Manometer



S.A.P (Italy) Brand Coolant Pump



Rotating Vise Flange



Easy Readable Angle Ruler



60 cm Long Material Stopper System



Aadjustable Bow Down Speed



Blade Bedding with Carbide and Bearings



Rotating Table



Hydromechanical Blade Tesion

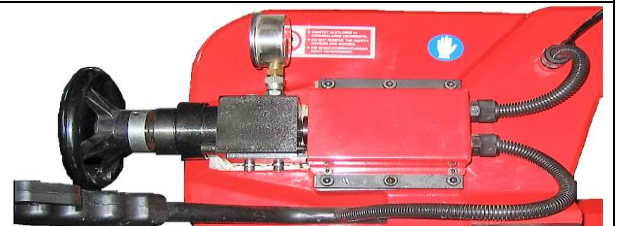

Bow Cover Switch



Blade Tension Switch



Levelling Foot Leg



Wheel Bedding with Bearing



Automatic Stop When;

- The covers are open
- Blade is broken
- Blade tension is low

SAFETY EQUIPMENTS AND ASSIGNMENTS

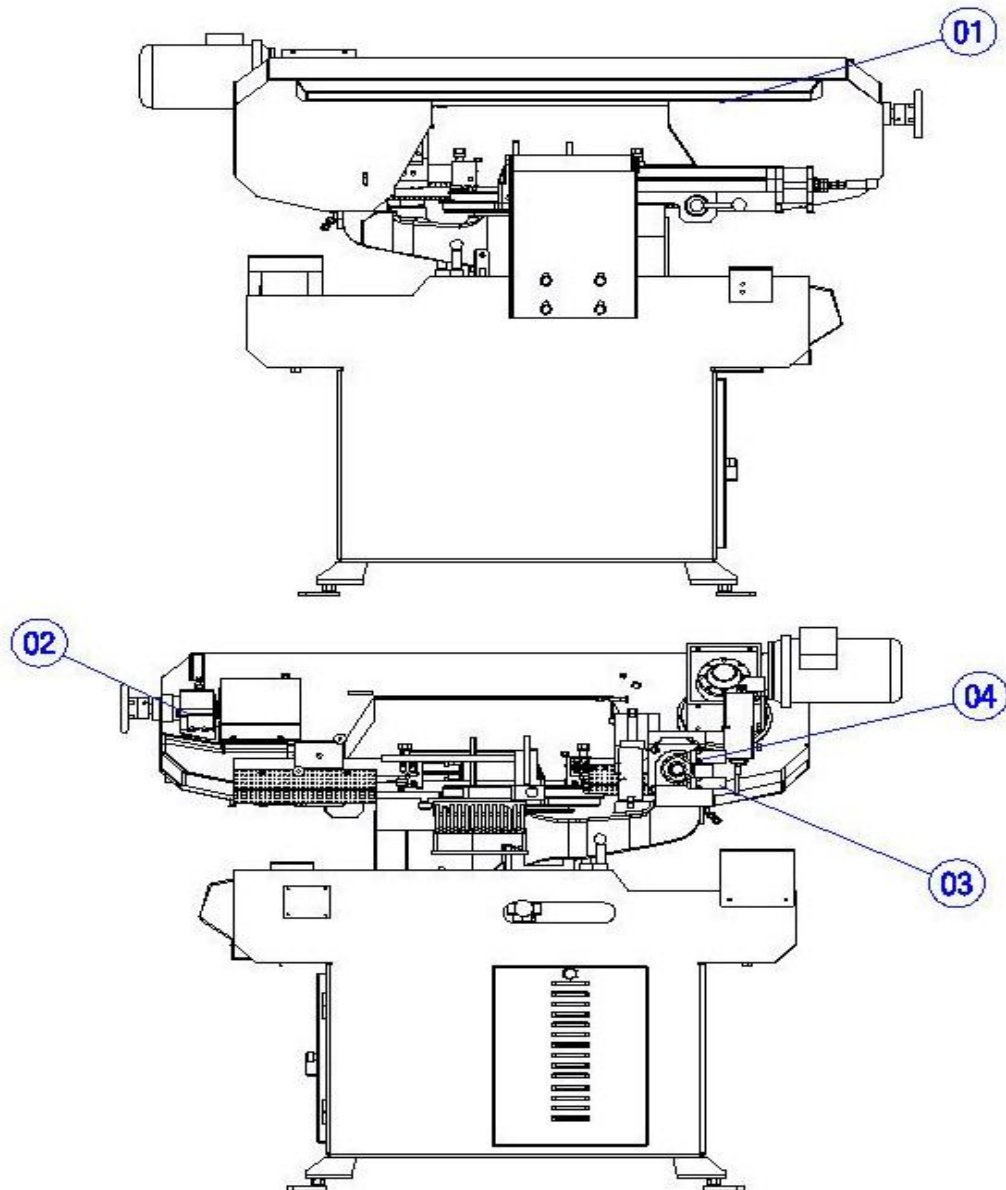

1	Lid Safety Switch
2	Break-off Switch
3	Down Limit Switch
4	Top Limit Switch

TERMS

Delivery (After Receipt of written PO) :

Type of Delivery : **Exwork**

WARRANTY CONDITIONS

The machine is under the warranty of KARMETAL LTD. ŞTİ. For a period of 2 years for mechanical parts, 1 year for electric and electronic parts from the date of purchase. This warranty is subject to all of the terms and conditions listed below:

1. This warranty is valid only if the **Warranty Registration Form** is filled in and returned to the manufacturer or its authorized dealer within **two months after the** date of purchase.
2. The obligation of the manufacturer under this warranty shall be limited to repairing or replacing components which proves defective and which our examination shall disclose to our satisfaction to be defective.
3. Defects due to improper operation, misuse, neglect, alteration, irregular voltage conditions, inadequate wiring, improper installation (**all electrical and electronic components, all electrical motors etc.**) and due to accidents or any damage caused by transportation, flood, fire, natural disasters, theft are not included in this warranty and are strictly the responsibility of the purchaser.
4. Any part returned to KARMETAL or its authorized dealer under the terms of this warranty shall be on the basis of transportation charges prepaid by the customer and must be accompanied by a record of the machine model code and serial number.
5. This warranty does not apply to the following components; band saw blade, blade pressure pads or brackets and blade guide bearings **because of being consumables**.
6. Manufacturer and authorized dealer cannot be blamed within maximum repair period for the material or moral damage. Apart from that act the period as Warranty Conditions and there will not be done any retroactive requirement.



KARMETAL SANAYI ve TICARET LIMITED SİRKETİ

HanlıMerkezMah. HatipSok. No:32

Arifiye/Sakarya/TURKEY

Phone: +90 264 276 59 16

Fax: +90 264 276 59 19

www.karmetal.com.trsales@karmetal.com.tr

Machine videos are available on:



KMT CRAFT 250X300 DM MANUAL DOUBLE MITER BAND SAW MACHINE